

**Compact infrared camera
for laser applications**

Features:

- Wide measurement range from 575 °C to 1900 °C without sub-ranges
- Special narrow-band spectral response at 800 nm ideal for almost all NIR and CO₂ laser processing applications
- High dynamic CMOS detector with up to 764 x 480 pixels resolution
- Up to 1 kHz frame rate for fast processes
- Real-time analog output with 1 ms response time
- Extensive software package and SDK included



Technical specifications

Optical resolution (switchable)/ Frame rate	764 x 480 pixels @ 32 Hz 382 x 288 pixels @ 80 Hz (switchable to 27 Hz) 72 x 56 pixels @ 1 kHz ¹⁾ 764 x 8 pixels @ 1 kHz (fast linescanning mode) ¹⁾	
Detector	CMOS (15 µm x 15 µm)	
Spectral range	780 – 820 nm	
Temperature range	575 °C ... 1900 °C (27 Hz mode) 625 °C ... 1900 °C (32 / 80 Hz mode) 750 °C ... 1900 °C (1 kHz mode)	
Optics	FOV @ 764 x 480 px: 41° x 25° (f = 16 mm) 27° x 17° (f = 25 mm)	FOV @ 382 x 288 px: 20° x 15° (f = 16 mm) 14° x 11° (f = 25 mm)
Thermal sensitivity (NETD)	< 2 K (<1000 °C/ 27 Hz to 1kHz) ²⁾	
Accuracy	±1 % of reading (<1500 °C)/ ±2 % of reading (>1500 °C) ³⁾	
PC interface	USB 2.0 / optional USB to GigE (PoE) conversion	
High speed analog output (@ 1 kHz mode)	0–10 V real time output of 8x8 pixels (1 ms response time)	
Standard process interface (PIF)	0–10 V input, digital input (max. 24 V), 0–10 V output	
optional Industrial process interface (PIF)	2x 0–10 V inputs, digital input (max. 24 V), 3x 0/4 – 20 mA outputs, 3x relays (0–30 V/ 400 mA), fail-safe relay	
Cable length (USB)	1 m (standard), 5 m, 10 m, 20 m 5 m and 10 m also available as high temperature USB cable (180 or 250 °C)	
Ambient temperature	5 °C ... 50 °C	
Storage temperature	–40 °C ... 70 °C	
Relative humidity	20–80 %, non-condensing	
Enclosure (size/ rating)	46 x 56 x 88 - 129 mm (depending on lens + focus position) / IP 67 (NEMA 4)	
Weight	245 - 311 g (depending on lens)	
Shock / Vibration ⁴⁾	IEC 60068-2-27 (25G and 50G) / IEC 60068-2-6 (sinus shaped), IEC 60068-2-64 (broadband noise)	
Tripod mount	¼–20 UNC	
Power supply	via USB	
Software	optris PIX Connect / IRmobile Android App	
Scope of supply (standard)	<ul style="list-style-type: none"> • USB camera with 1 lens • USB cable (1 m) • Table tripod • PIF cable (1 m) incl. terminal block • Aluminum case 	<ul style="list-style-type: none"> • Software package optris PIX Connect • Optional: CoolingJacket, High temperature cable, protective window

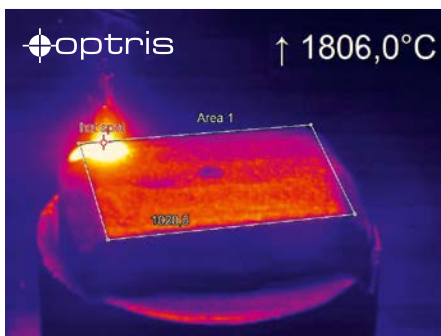
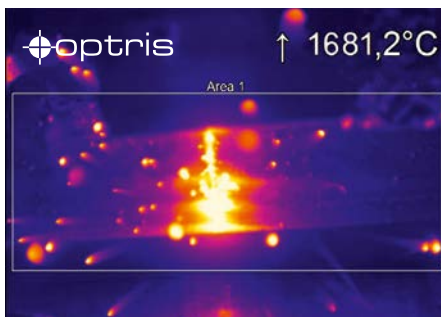

Image: SLV Halle GmbH, Deutschland 2018



For further information as well as the product configurator, please visit:
www.optris.global/thermal-imager-pi-08m

¹⁾ Can be placed anywhere within the full FOV ²⁾ <4 K (>1000 °C/ 27 Hz to 1 kHz)

³⁾ for 1 kHz mode: ±1.5 % of reading (<1500 °C) / ±2.5 % of reading (>1500 °C)

⁴⁾ For more details see operator's manual

optris PI 08M

Dimensions in mm

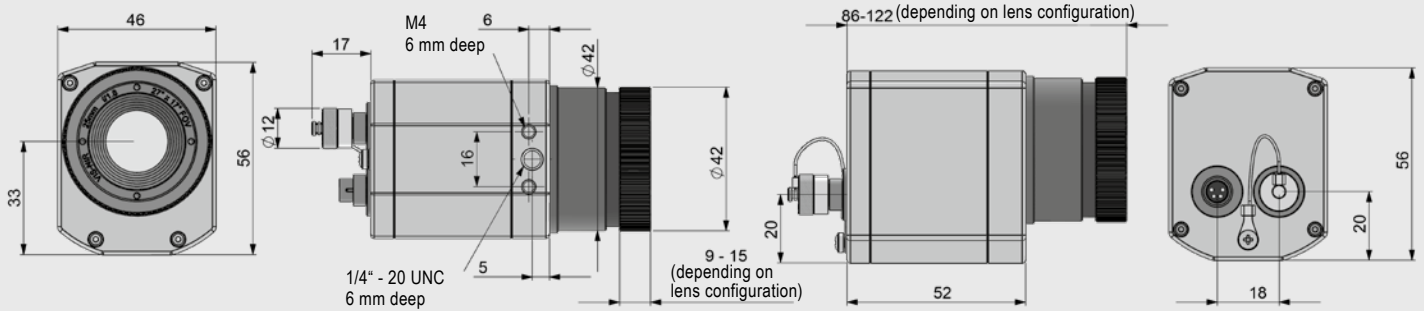

Process integration

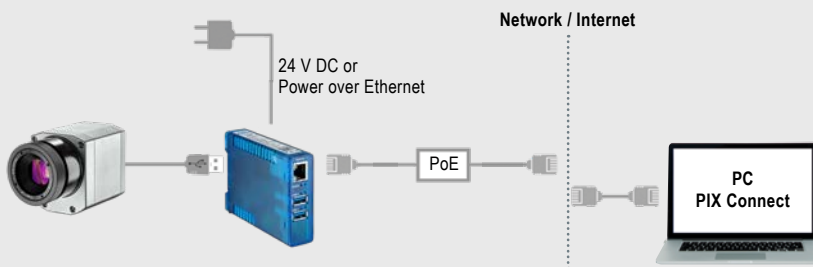

optris USB Server Gigabit 2.0

- Network connection via Gigabit Ethernet
- Full TCP/IP support incl. routing and DNS
- Two independent USB ports
- Power over Ethernet or external voltage supply at 24 - 48 V DC
- Galvanic isolation 500 V_{RMS}
- Remotely configurable via web based management

For further information please visit www.optris.global/usb-server-gigabit

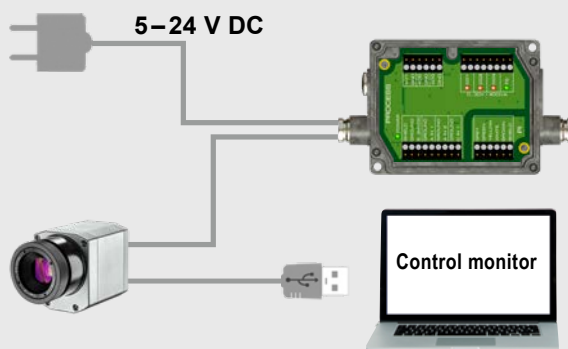

optris Industrial process interface

- Use of camera for process monitoring in industrial environments
- Continuous fail safe monitoring of imager, software and cable connections
- 3 analog/ alarm outputs, 2 analog inputs, 1 digital input, 3 alarm relays, 1 fail-safe relay

For further information please visit www.optris.global/neu-industrial-process-interface

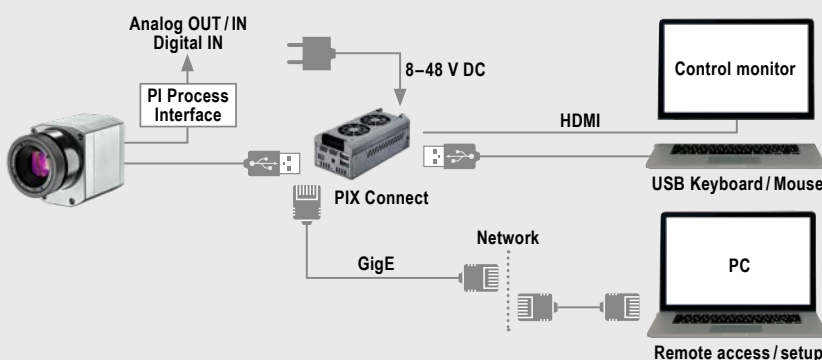

optris PI NetBox

- Miniature PC as add-on to the PI series for stand-alone system
- Integrated hardware and software watchdog
- Connections: 3x USB 2.0, 1x Mini-USB 2.0, Micro-HDMI, Ethernet (Gigabit Ethernet), micro SDHC / SDXC card

For further information please visit www.optris.global/pi-netbox